

VITOLUPO

ITALIAN ARTDESIGN

IL CASTAGNO

TAVOLINO BASSO | COFFEE TABLE

by Fabio Crippa & Joe Gentile



L'immagine evocativa da cui nasce questo prodotto è quella di ninfee galleggianti sullo specchio d'acqua. Il piano in ottone lavorato a cerchi concentrici evoca movimenti acquatici e dona alla superficie riflessi dorati. La lavorazione a rilievo rimanda a pennellate dense tipiche dell'Impressionismo. L'incastonatura della pietra semipreziosa Labradorite rende il manufatto più affascinante e crea, attraverso l'iridescenza della stessa, effetti cromatici che rimandano alle più famose ninfee di Monet. I piani in cristallo fumé invitano a "guardare" al di là della superficie alla ricerca di tesori sommersi.

The evocative image that gave rise to this coffee table is that of lilies floating on the surface of the water. The brass concentric circles of the tabletop recall the ripples of a stone dropped in the water and imbue the surface with glimmering gold reflections. The surface relief suggests thick Impressionist brushstrokes. The Labradorite inlays heighten the fascination of the object and, through their iridescence, generate chromatic effects that call to mind Monet's celebrated water lilies. The smoked glass invites the gaze beyond the surface, in search of sunken treasures.

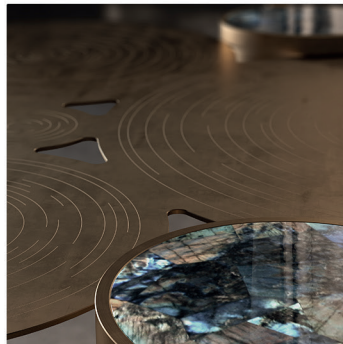
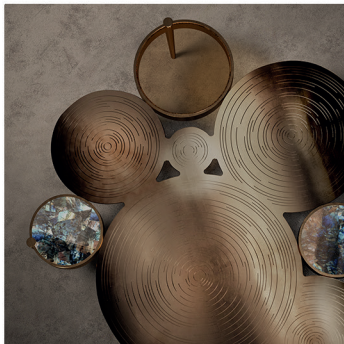

IL SAMBUCO

TAVOLINO BASSO | COFFEE TABLE

dimensioni | dimensions L151 x P108 x H35 cm
peso | weight 70 kg
volume | volume 0,90 m³

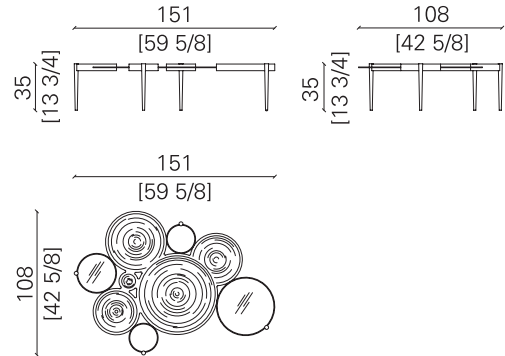

Tavolino con piano e piedini in ottone in finitura bronzata. Il piano è impreziosito in superficie con decorazione a cerchi concentrici in fresata con inserti di pianetti in pietra semipreziosa Labradorite e pianetti in vetro bronzato temperato.

Coffee table with top and legs in bronzed brass. The top is enhanced on its surface by concentric milled circle decorations, with inserts in semi-precious Labradorite stone, and tempered bronzed glass.

finiture | finishes

inserti piano in
pietra semipreziosa
top inserts in
semi-precious stone

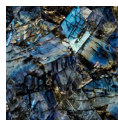

PS01
Labradorite

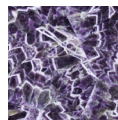

PS03
Ametista
Amethyst

inserti piano in vetro
glass inserts

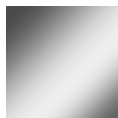

VE01
vetro extrach.
extra-clear
glass



VE02
vetro bronzato
bronzed
glass



VE03
vetro fumé
smoked
glass

piano e struttura in ottone
brass top and structure



ME01
bronzato
bronzed

composizioni | compositions

Finitura come da immagine.
Finish as shown in image.

Altre finiture disponibili su richiesta. | Other finishes available upon request.

IL CASTAGNO

POLTRONA | ARMCHAIR

cuscini | cushions

cuscino strutturale
50x50 cm x 1pz
structural cushion
50x50 cm x 1 pc

Imbottitura cuscini in piuma d'oca. Profilo in tinta o in contrasto.
Ducks' down cushion filling. Matching or contrasting piping.

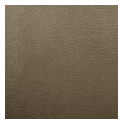

+ altri colori
+ other colours

NK2132
pelle nabuk
nabuck leather

cuscino decorativo A
50x50 cm x 1pz
decorative cushion A
50x50 cm x 1 pc

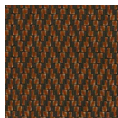

+ altri colori
+ other colours

MSPT201
tessuto intrecciato
plaited fabric

cuscino decorativo B
50x50 cm x 1pz
decorative cushion B
50x50 cm x 1 pc

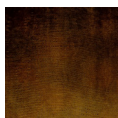

+ altri colori
+ other colours

MSPE701
velluto
velvet

cuscino decorativo C
40x40 cm x 1pz
decorative cushion C
40x40 cm x 1 pc

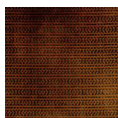

+ altri colori
+ other colours

MSAN601
velluto
velvet

Altre finiture disponibili su richiesta. | Other finishes available upon request.