

VITOLUPO

ITALIAN ARTDESIGN

L'AGRIFOGLIO

SEDIA | CHAIR

by Fabio Crippa & Joe Gentile



Questa sedia coniuga la maestria della lavorazione del legno con l'artigianalità della lavorazione della pelle. Le forme morbide e avvolgenti conferiscono alla seduta una armonia e una sensualità che la rendono piacevole alla vista e al tatto tipica degli interni del car design più lussuoso. La lavorazione del pellame è ottenuta attraverso una sorta di incastonatura nella struttura lignea che ne viene avvolta creando una vera e propria seconda pelle. Nella versione con il bronzo, si arricchisce attraverso l'inserimento di un dettaglio in bronzo del bracciolo.

This chair combines fine woodworking skills with the craftsmanship of leather processing. The soft and enveloping forms lend the seat an harmony and a sensuality that make it pleasing to the eye and to the touch, as is typical of the interiors of the most luxurious car designs. The leatherwork was done by means of a sort of inlay technique, wrapping the leather around the wood framework, creating an actual second skin. In the bronze version, the chair is enriched through the inclusion of a bronze detail in the armrest.



L'AGRIFOGLIO

SEDIA VARIANTE 1 | CHAIR VARIANT 1

dimensioni | dimensions L57 x P61 x H85 cm
peso | weight 22 kg
volume | volume 0,46 m³

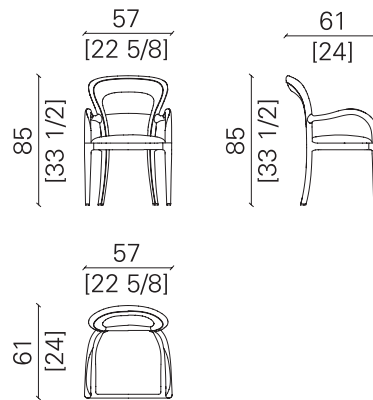

Sedia in massello di noce americano tinto scuro opaco. Imbottitura schienale, interno gambe posteriori, seduta e profilo in pelle con cuciture in tinta. Bracciolo in fusione di bronzo con inserto in pelle con cuciture in tinta. Puntalini in ottone in finitura satinata.

Chair in dark solid American walnut in matt finishing. Backrest, rear legs inner side, seat and profile upholstered in leather with matching stitching. Armrest in bronze casting, with insert in leather with matching stitching. Tips in brass with satin finish.

finiture | finishes

struttura in noce americano
opaco
matt American walnut structure

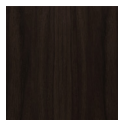

NA01.M
noce amer.
scuro opaco
matt dark
American walnut

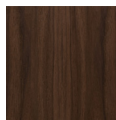

NA02.M
noce amer.
naturale opaco
matt natural
American walnut

imbottitura in pelle
leather upholstery

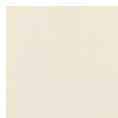

ZF01634
pelle
leather

+ altri colori
+ other colours

bracciolo
armrest

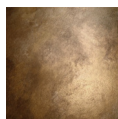

FU01
fusione di bronzo
bronze casting

puntalini in ottone
brass tips



ME02
bagno oro lucido
shiny gold
plated



ME03
satinato
satin finish

composizioni | compositions

Finitura come da immagine.
Finish as shown in image.

Altre finiture disponibili su richiesta. | Other finishes available upon request.

L'AGRIFOGLIO

SEDIA VARIANTE 2 | CHAIR VARIANT 2

dimensioni | dimensions L57 x P61 x H85 cm
peso | weight 8 kg
volume | volume 0,46 m³

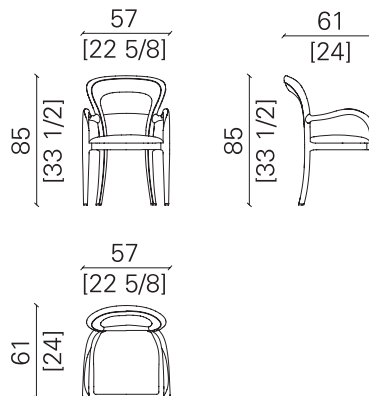

Sedia in massello di noce americano tinto scuro opaco. Imbottitura schienale, interno gambe posteriori, seduta e profilo in pelle con cuciture in tinta. Bracciolo in massello di noce americano tinto scuro opaco con inserto in pelle con cuciture in tinta. Puntalini in ottone in finitura satinata.

Chair in dark solid American walnut in matt finishing. Backrest, rear legs inner part, seat and profile upholstered in leather with matching stitching. Armrest in dark matt solid American walnut, with inlay in leather with matching stitching. Tips in brass with satin finish.

finiture | finishes

struttura in noce americano
opaco
mat American walnut structure

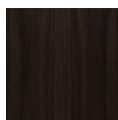

NA01.M
noce amer.
scuro opaco
matt dark
American walnut

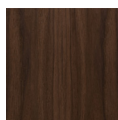

NA02.M
noce amer.
naturale opaco
matt natural
American walnut

imbottitura in pelle
leather upholstery

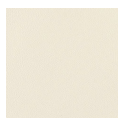

ZF01634
pelle
leather

+ altri colori
+ other colours

puntalini in ottone
brass tips



ME02
bagno oro lucido
shiny gold
plated



ME03
satinato
satin finish

composizioni | compositions

Finitura come da immagine.
Finish as shown in image.

Altre finiture disponibili su richiesta. | Other finishes available upon request.

L'AGRIFOGLIO

SEDIA VARIANTE 3 | CHAIR VARIANT 3

dimensioni | dimensions L57 x P61 x H85 cm
peso | weight 8 kg
volume | volume 0,46 m³

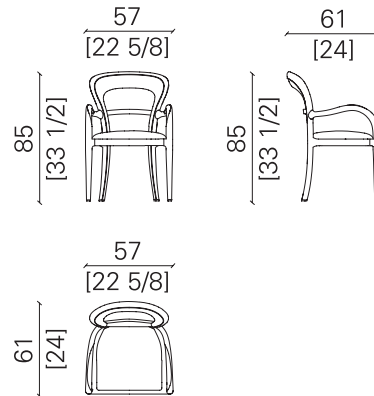

Sedia in massello di noce americano naturale opaco. Schienale in massello a vista, seduta in pelle con cuciture in tinta, profilo in cuoietto intrecciato. Bracciolo in massello di noce americano naturale opaco con inserto in pelle con cuciture in tinta. Puntalini in ottone in finitura satinata.

Chair in dark solid American walnut in natural finishing. Backrest with solid wood finish, seat in leather with matching stitching, piping in plaited leather. Armrest in natural matt solid American walnut, with inlay in leather with matching stitching. Tips in brass with satin finish.

finiture | finishes

struttura in noce americano
opaco
matt American walnut structure

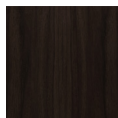

NA01.M
noce amer.
scuro opaco
matt dark
American walnut

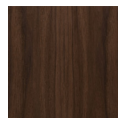

NA02.M
noce amer.
naturale opaco
matt natural
American walnut

imbottitura in pelle
leather upholstery

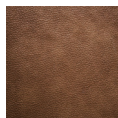

ET5081
pelle
leather

+ altri colori
+ other colours

puntalini in ottone
brass tips



ME02
bagno oro lucido
shiny gold
plated



ME03
satinato
satin finish



profilo intrecciato
in cuoietto
plaited leather piping

composizioni | compositions

Finitura come da immagine.
Finish as shown in image.

Altre finiture disponibili su richiesta. | Other finishes available upon request.